

# WOYO

## SMARTER EASIER

---

Paintless Dent Repair  
PDR007(Iron)  
**Manual**

[WWW.WOYOSMART.COM](http://WWW.WOYOSMART.COM)

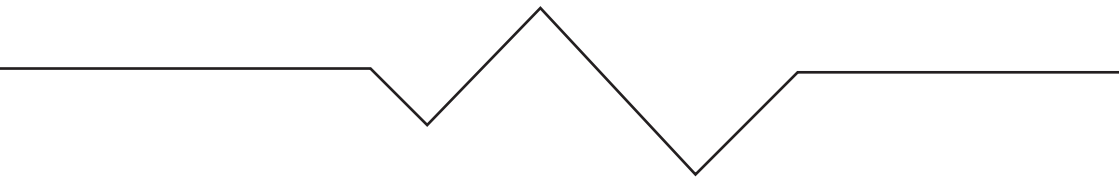

---

# Video

Scan QR code, to study how to use it quickly,  
to help you earn more profits.



# Paintless Dent Repair 007 Iron

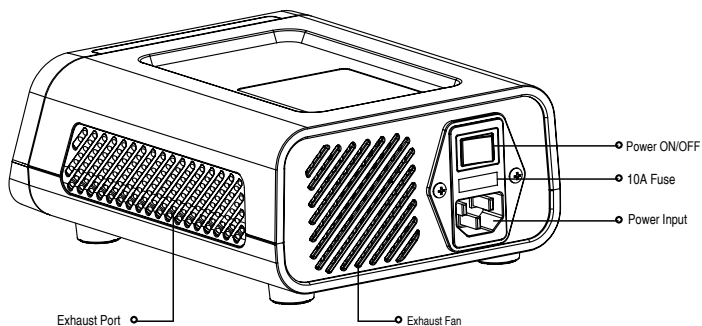
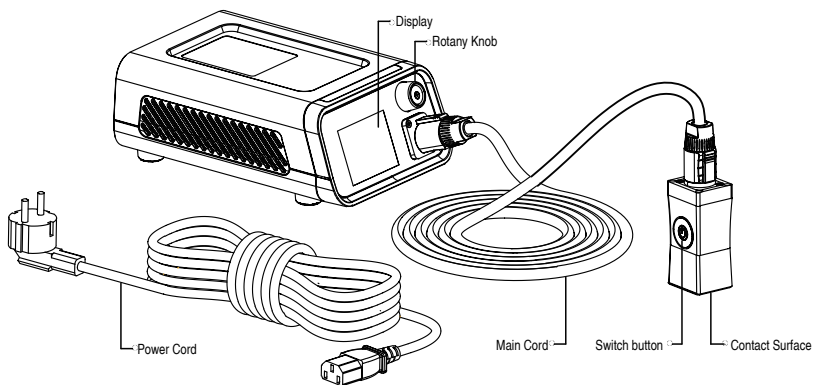

**Before using this device, you must read the instructions. If the instructions are not followed carefully, the operator could suffer injury, the device could be damaged, or the car being treated might be damaged.**

## **Attention before use(Warning)**

1. Not suitable for operation by those with pacemakers or artificial limbs with metal parts.
2. Before using this device, you must wear a safety mask, safety gloves, and safety clothing to avoid being burned during use.
3. Operators must not have any metal objects on their person during operation, including but not limited to watches, cuff links, keys, belt buckles, coins, or zippers.
4. This device cannot be operated in areas with conductive particulate matter, areas used for applying paint, areas housing or handling chemical fuels, areas of high temperature, and areas of high humidity.
5. Once the device is powered on, flammable objects must be kept away from the device.
6. Before you power on the device, make sure that you have a fire extinguisher on hand in case any misoperation causes a fire.
7. Do not use this device in the vicinity of safety airbags.
8. Once the device is powered, there must be personnel on site to watch over the device. When the device is not in use, unplug the device's power cable.
9. This device should be stored at temperatures between 0 and 50 celsius. When transporting the device, avoid vibrations or shocks.

## **Attention in using (Warning)**

1. While the restoration head is restoring a damaged car body, the temperatures of both the restoration head and the body will rapidly increase. Do not touch either the restoration head or the car body before they have had time to cool down.
2. While the restoration head is in the process of restoration, the temperatures of both the restoration head and the damaged area will rapidly increase. Using the restoration head on one area for too long may increase temperatures to the point of damaging the car's paint job (it is recommended that every 1-1.5 seconds, the operator wipes down the damaged area with a wet rag in order to keep the temperature manageable).
3. During the restoration process, the temperatures of both the restoration head and the damaged area will rapidly increase and the body of the car will immediately become softer. During restoration, make sure the restoration head is not applying pressure to the car, otherwise the restoration process itself might further dent the car.

## 1.Installation

1.1 Connect the cord to the repair head and PDR009 main. Aim at the location socket and insert one end of the cord, turn the end clockwise to tighten the cord securely.

1.2 Connect the power cord to the backside of the PDR009 main.

1.3 Make sure that all the cords are well connected before connect the machine to the power socket. Switch on the backside of the PDR009 main.

## 2.Self-check System

The machine is activated when turn on the power switch and then it get into the self-checking state. The machine can automatically check if the input frequency and voltage are in accordance with the applicable regulations or not before it is used. There will be an error warning accordingly if something goes wrong.

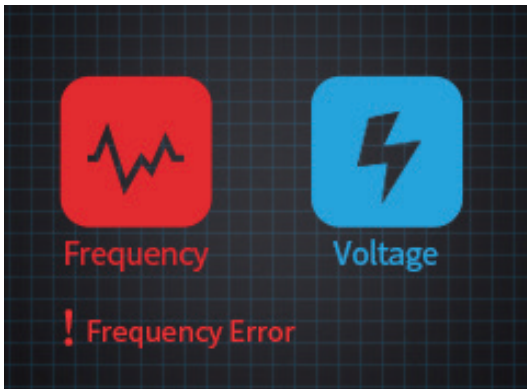

2.1Frequency Error: Please stop using the machine and contact your reseller or WOYO SMART CO.,LTD.

2.2Voltage Error: Please check if the input voltage are in accordance with the applicable regulations. If yes, please contact your reseller or WOYO SMART CO.,LTD.

2.3 The machine is standby and ready to use when input frequency and voltage are applicable.

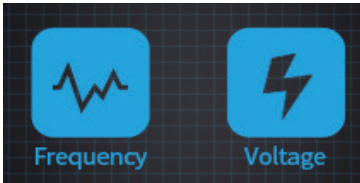

### 3.Standby

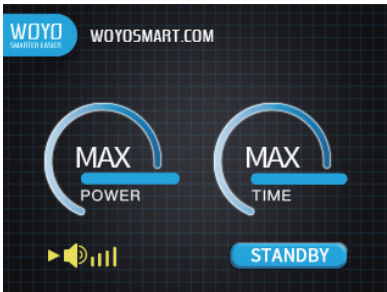

Turn the rotary knob to select your expected parameter sign. Press the rotary knob, there will appear a triangle sign, indicates the current parameter is available to set when you turn the rotary knob. Press the rotary knob again, the triangle sign disappeared indicates that the machine recover to the parameter selection state again.

### Parameter Range

3.1 Power: OFF, 10%, 20%, 30%, 40%, 50%, 60%, 70%, 80%, 90%, MAX

3.2 Time: 1.0S, 1.5S, 2.0S, 2.5S, 3.0S, 3.5S, 4.0S, 4.5S, 5.0S, MAX

3.3 Triangle sign: Indicates the current parameter is selected and available to preset when you turn the rotary knob.

3.4 Volume: 0, 1, 2, 3, 4

## 4.Working Status and Error Instruction

4.1Standby

4.2Operating

4.3Wrong operation. There is an air gap between the repair head and the work piece.

4.4The input voltage supplied is not stable. Please check the voltage is is normal or not.

4.5The operating temperature is overheat. Please stop use the machine and let it cool down adequately before use again.

4.6Please contact your reseller or WOYO SMART CO.,LTD.



## 5. Suitable range of use

This device is designed specifically to be used with dents on flexible steel car bodies. The diagrams below illustrate the types of dents that can be removed. Dents like the kind caused by impact from hailstones, which leave smooth, rounded dents, can be removed. (More active materials may call for different devices, like pull hooks or suction cups. Consult with training personnel for specifics)



## 6. Unsuitable range of use

- 6.1 Sharp dents
- 6.2 Body areas that have been damaged and reconstructed
- 6.3 Crumpled/creased areas or dents along creased metal
- 6.4 Aluminum bodies

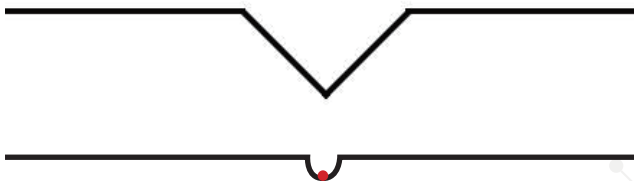

## 7. Dent repair method

Car body dent diagram

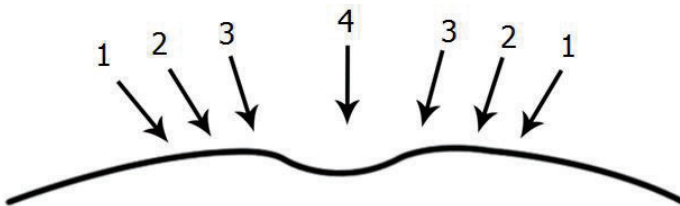

# Paintless Dent Repair Manual Diagrams

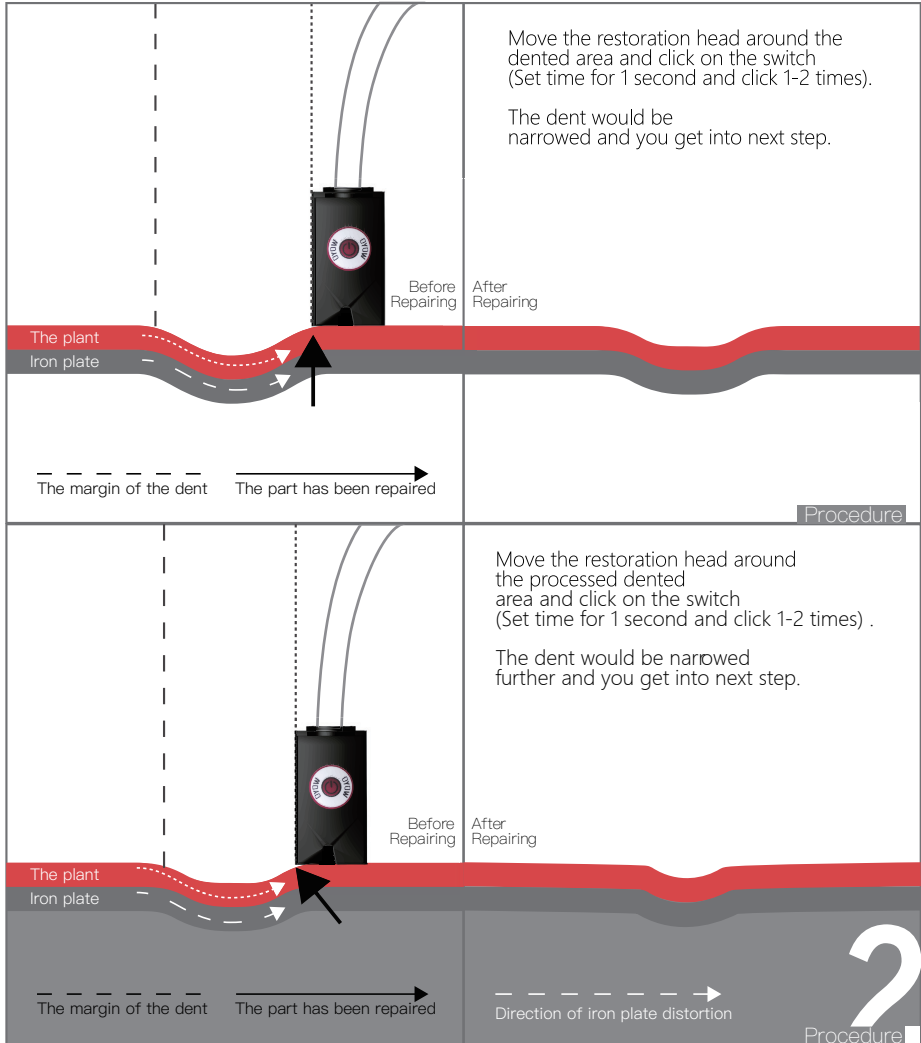

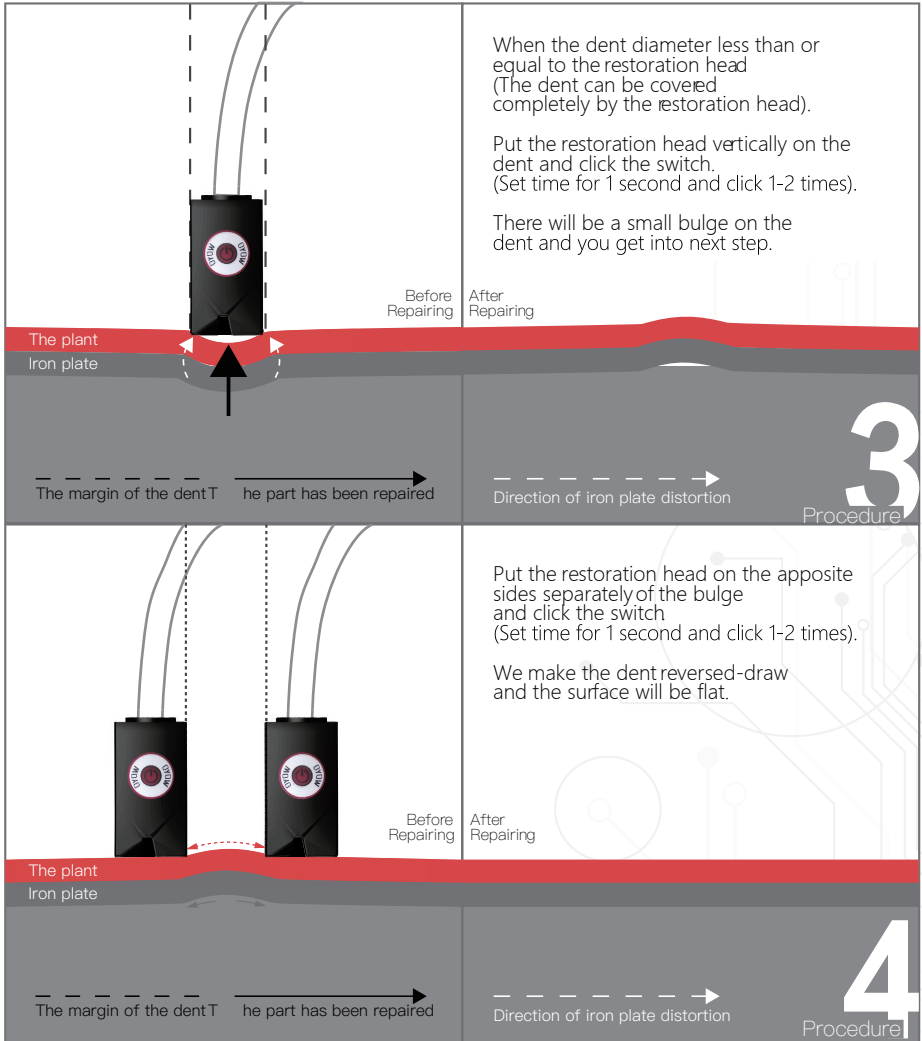

## 握友·免伤漆凹痕修复仪使用说明 设备介绍

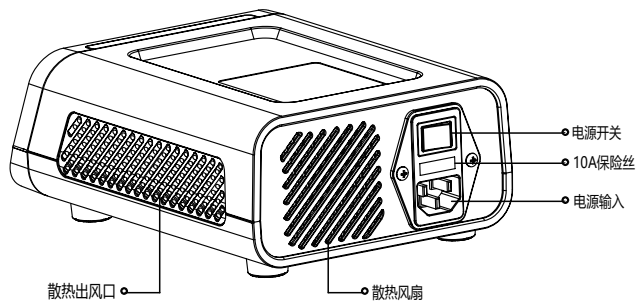
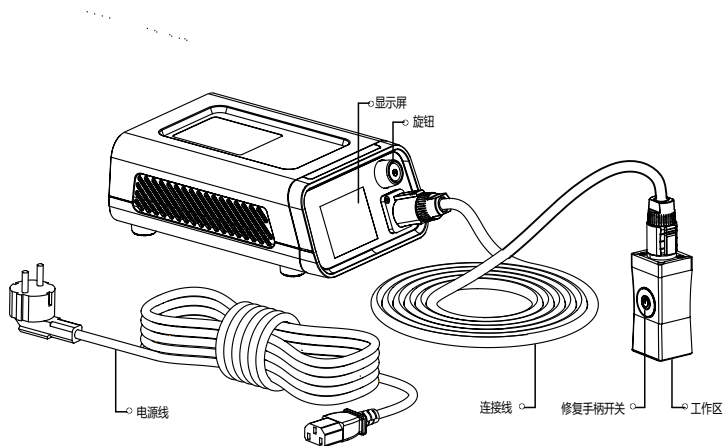

**使用设备前，务必先阅读说明书，任何违背说明书的操作都可能导致操作人员受伤、设备受损，以及车身受损。**

## 操作前警告（必须看）

1. 安装心脏起搏器和各种含有金属假肢的患者请勿使用此设备。
2. 使用设备前，请佩戴好防护面罩、防护手套和工作服防止操作中烫伤。
3. 使用人员不可佩戴任何金属物品，如手表，项链，钥匙，皮带扣，硬币，拉链等。
4. 设备不可在有导电性粉尘，喷涂工作区，化工燃料工作区，高温区，高湿度区下工作。
5. 设备通电后，旁边不可放置可燃物。
6. 设备使用前，请备有灭火器，以防操作不当引发的意外火情。
7. 不要在装有安全气囊附近区域使用此工具。
8. 如设备接通电源后，需有人看守设备。不使用时，请拔下设备的交流电源插座。
9. 设备存放，温度要保持在 0-50 摄氏度，当移动设备时要避免震动。

## 操作中重要警告（必须看）

1. 修复头在修复受损车身过程中，修复头和车身温度会迅速升高，在设备、车身、修复头没有冷却之前，请不要用手触摸，以免烫伤。
2. 修复头在修复过程中，修复头和车身温度会迅速升高，单个受损部位请勿长时间操作（可每操作 1-1.5 秒后用湿毛巾反复擦拭受损部位，以此降温），以免温度过高伤及车漆。
3. 修复过程中，修复头和车身温度会迅速升高，车体会产生瞬间微弱软化，期间注意修复头不要有下压动作，以免在瞬间软化造成凹陷部位加大。

## 适应范围

设备仅针对有弹性的钢铁金属车体凹陷有效，以下图为例，凹陷形状类似冰雹砸伤车身后产生的圆润凹陷（更多活性坑体需配合其他设备，如勾子 拉拔器 吸盘等，请咨询培训师）



## 不适应范围

- 以下死角和拉伸程度过大的凹陷不适用
- 漆面有过创伤，已钣金过的车身部位不适用
- 对于车漆一些折痕部位或者折线筋线有直角弯曲部位不适用

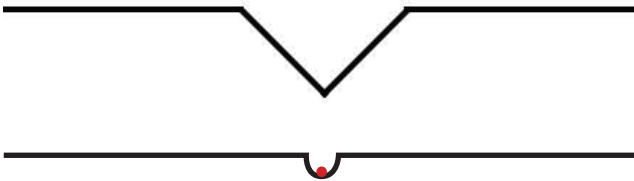

## 凹陷修复方法

车身凹陷示意图

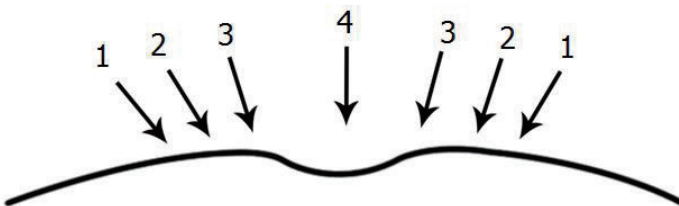

首先根据凹陷的大小和车漆颜色来设定免伤漆凹陷修复仪的工作时间或功率，一般设定【时间 / 功率旋钮】至 1 秒档位，手持修复头，按下【工作开关】依次序围绕凹陷区四周，先围绕 1 点四周依次到 4 点加热，等待冷却；然后围绕 2 点依次到 4 点加热，等待冷却；再围绕 3 点依次到 4 点加热，等待冷却；最后集中在 4 点加热，等待冷却；修复完毕。（部分区域可能需要多次重复以上动作）

使用过程中，必须注意不要在同一个区域工作时间超过 1 秒，建议在工作区操作中使用压缩空气或湿毛巾来冷却车身。修复中会产生大量热量，车身金属会发生软化，不要向下用力，以免导致凹陷区域加大。修复过程中必须注意车身表面温度，过热会燃烧损坏车漆，带来更大的伤害。建议用户先在一个不使用的发动机机盖练习，这样您会更快了解设备性能，以及潜在风险。

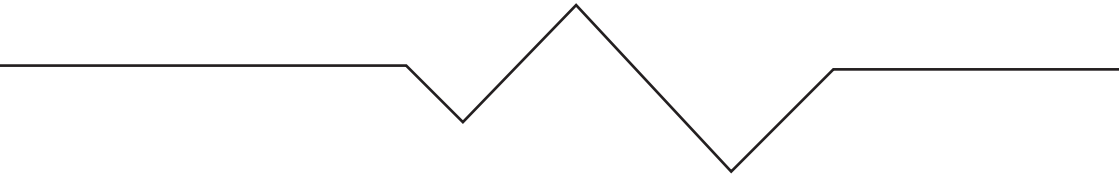



---

# Video

Scan QR code, to study how to use it quickly,  
to help you earn more profits.



**Model:** PDR 007      **Manufacturers:** WOYO SMART CO.,LTD  
**Email:** INFO@WOYOSMART.COM  
**Add:** Xitou Industrial Park,Longhua,Shenzhen,CHINA

**WOYO**  
**SMARTER EASIER**  
**WWW.WOYOSMART.COM**